

Surface Track

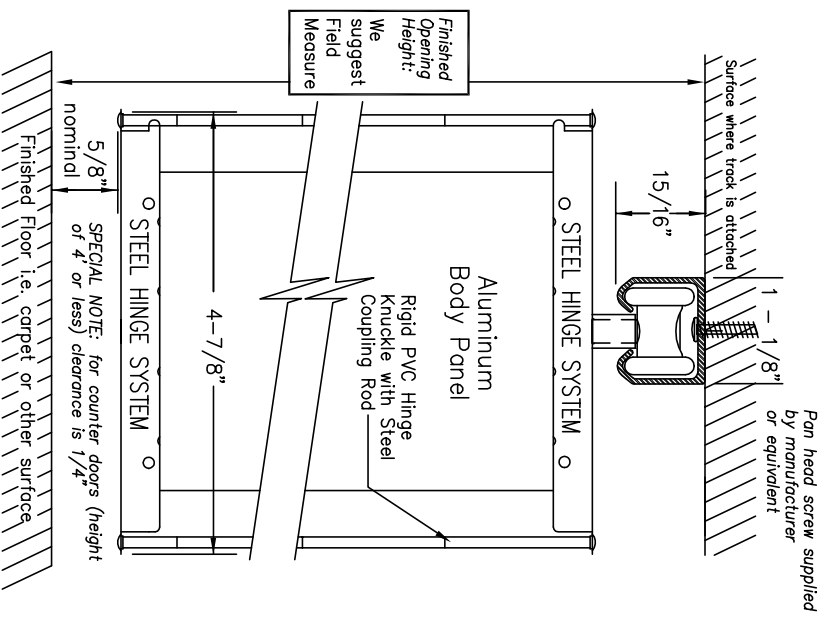

Recessed Track

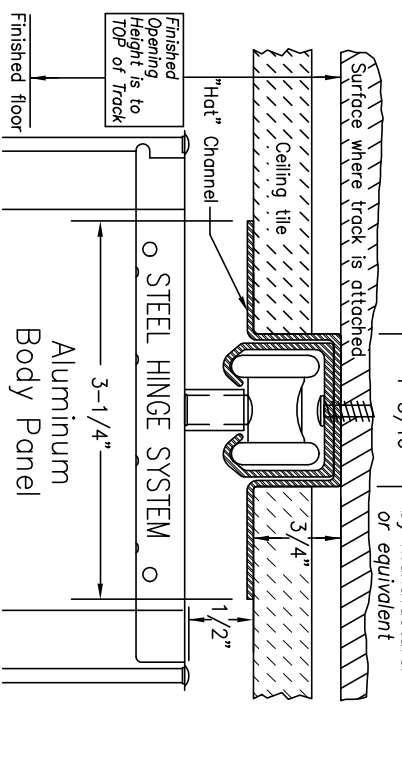

I-Beam Track

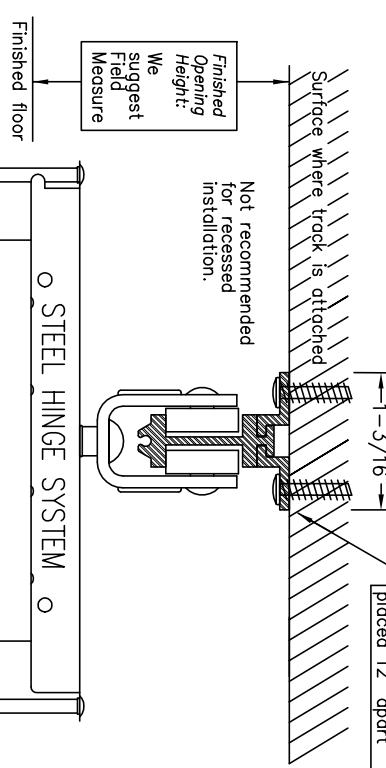

Door Types

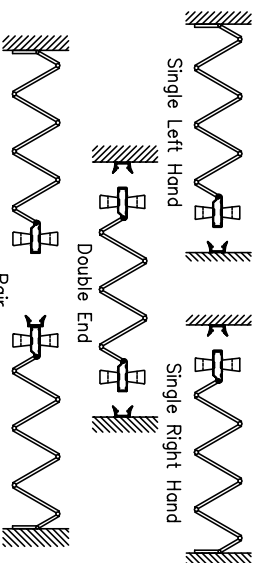

Lead Post

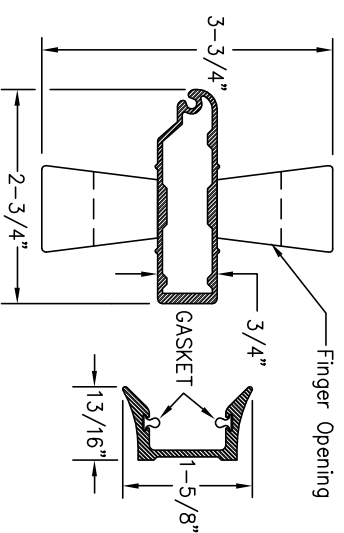

Sliding Jamb Option

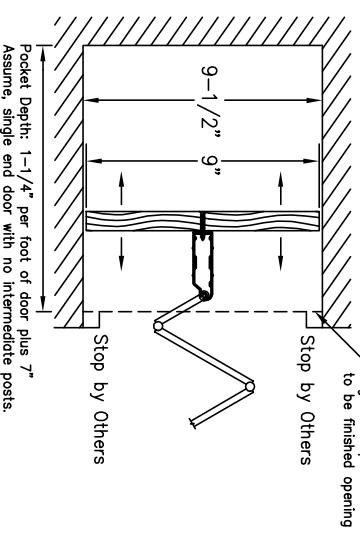

Mounting Panel

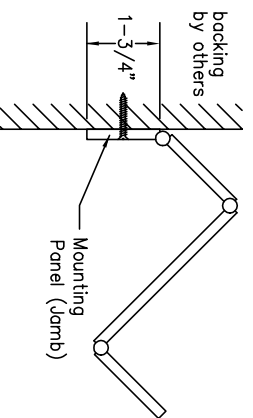

Multiple Meeting Option

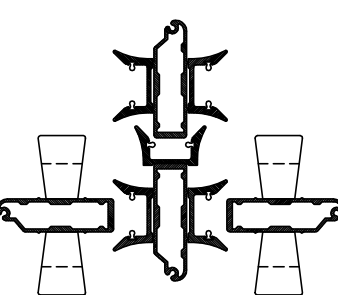

Stack Dimensions

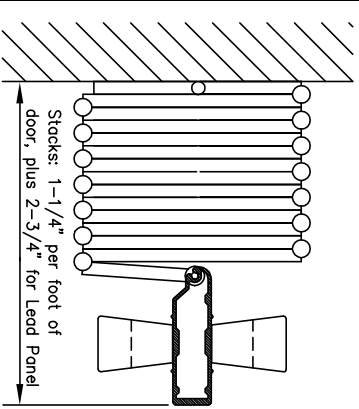

Intermediate Rolling Post

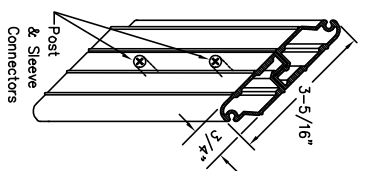

Privacy Latch

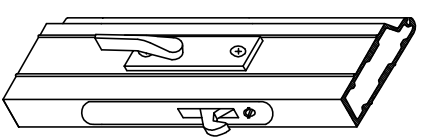

Keylock

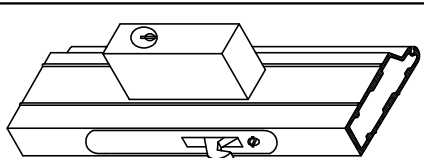

Single Cremone Bolt Keylock

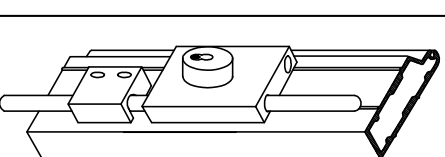

Double Cremone Bolt Keylock

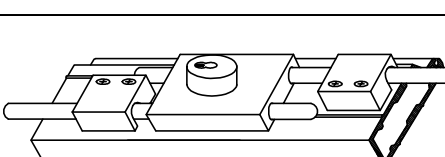

INFORMATION

Width Custom made to any width  
 Height Custom made to 10' - 1"  
 Panels Aluminum: Solid or Perforated  
 Side Channel Aluminum: Clear  
 Panel Connector Rigid Viny: Clear  
 Coordinated with side channel  
 Steel: Clear  
 Hinge System Ball bearing nylon wheels on steel axes  
 Wheels Aluminum (straight or curvable); Clear  
 Track Aluminum (straight only); White  
 Recessed Channel/  
 "Hat" Channel Aluminum: Clear  
 Lead, Intermediate and Jamb Deadlatch with Key Lock two sides  
 Latch Construction Details by Others  
 Header Height: 6'-8"  
 Door Weight Average Weight: 10lbs. Per lined foot  
 8-1" 12lbs. Per lined foot  
 10'-1" 15lbs. Per lined foot

See Woodfold Accordion Door brochure for additional details

Catch/Lock Options

Magnet with strike plate  
 Privacy Latch Deadlatch with thumb turn one side  
 Springlatch Springlatch with thumb turn two sides  
 Keylock 1 Side Deadlatch with thumb turn one side, keylock one side  
 Key and Single Bolt Key and single bolt lock  
 Key and Double Bolt Key and double bolt lock  
 Single Cremone Single Cremone Bolt with Key Lock  
 Double Cremone Double Cremone Bolt with Lock  
 Footbolts Locking or non locking  
 Other Keyed Options Keyed alike, custom keyed, construction core  
 Contact manufacturer for more details

Job Name: \_\_\_\_\_  
 Job Location: \_\_\_\_\_  
 Supplier: \_\_\_\_\_  
 Architects Acceptance

| Qty. | Single/Pair | Single End/Double End | Left or Right Stack | Width X Height | Finish/Color | Comments |
|------|-------------|-----------------------|---------------------|----------------|--------------|----------|
|      |             |                       |                     |                |              |          |
|      |             |                       |                     |                |              |          |
|      |             |                       |                     |                |              |          |

THESE SPECIFICATIONS ARE SUBJECT TO CHANGE WITHOUT NOTICE

THESE SPECIFICATIONS ARE SUBJECT TO CHANGE WITHOUT NOTICE

Woodfold—Marco Mfg. Inc.  
 P.O. Box 346 Forest Grove, OR. 97116  
 http://www.woodfold.com

Phone: 503-357-7181  
 Fax: 503-357-7185  
 740 SD 6/03